

Domestic RO Unit

Installation and Maintenance Manual

Good water, Diamond life



RO-50G/75G/80G/100G/125G

SAFETY INSTRUCTIONS

This appliance is intended to operate and function as per the instructions in this manual. It is not designed to operate outside of the specifications listed and any attempt to do so or tamper with the unit can cause damage to the unit and/or bodily harm. This unit is not a toy keep out of reach from small children. If the unit requires service or repair, please contact your local service technician or sales representative.

- Please ensure feed water temperature is over 4°C. Using water below 4°C can cause ice to form and damage the unit.
- Please ensure power source is correct before connecting unit. Incorrect voltage could result in damage to unit and/or fire hazard. Do not use unit if the power cord is damaged.
- A damaged power cord could cause an electrical shock or fire hazard. If power cord is damaged, unplug and discontinue use immediately.

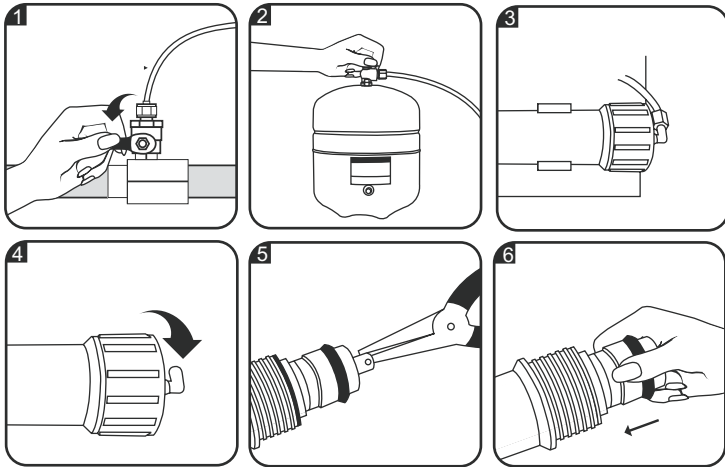

TROUBLESHOOTING

PROBLEM	CAUSE	SOLUTION
No product water	Water supply is off	Turn on feed water
Not enough product water	Water supply is blocker	Clear restriction
	Feed water valve is plugged	Open valve or unplug
	No drain flow	Clear or replace check valve
Pump not running	Low feed water pressure	Check source water supply
	No power supply or loose connection	Turn on power supply
	Transformer burnt out	Replace filter cartridges
Pump is running but system is not producing water	Pre-filters plugged	Replace filter cartridges
	Inlet solenoid valve not working	Repair or replace valve
System does not shut off	Auto shut off switch not working	Repair or replace switch
Abnormal pump noise	Pre-filters plugged	Replace filter cartridges
	Low feed water pressure	Adjust feed water pressure
No drain water	Plugged drain flow restrictor	Replace
Tubing leaks	Tubing connection incorrect	Check/reinstall tubing
	Defective or damaged tubing	Replace section of tubing

CONTENTS:

1. INTRODUCTION
2. PACKAGE CONTENTS
3. TECHNICAL SPECIFICATIONS
4. BEFORE YOU START
5. HOW YOUR SYSTEMS WORKS
6. SYSTEM COMPONENTS
7. INSTALLATION
8. OPERATION AND MAINTENANCE
9. TROUBLE SHOOTING
10. SAFETY INSTRUCTIONS

INTRODUCTION

We would like to thank you for choosing the A/B/C Series Standard Reverse Osmosis Unit. This is our standard 5-stage filtration unit with optional 6th stage filtration add-on. Our unit has been manufactured to strict quality standards to ensure you receive the best product possible. This unit is your first step to cleaner, healthier and better tasting water. The stages and their functions are outlined below.

First Stage: Spun PP Filter – removes larger particles suspended in water.

Second Stage: Granular Carbon Filter – removes organics, chlorine, odor, and turbidity.

Third Stage: Block Carbon Filter – further removes any organics, chlorine, odor and turbidity.

Fourth Stage: RO Membrane – removes bacteria, heavy metals, dissolved matter, and salinity.

Fifth Stage: Inline Carbon Filter (post filter) – adjusts the taste of treated water.

Optional Sixth Stage add-ons include:

Mineralized Ball Filter – reincorporates healthy minerals back in to treated water.

Ultraviolet Sterilizer – kills any bacteria, virus, or organisms present in water.

PACKAGE CONTENTS

Reverse Osmosis Unit – 1 pcs

Housing Wrench – 1 pcs

Food Grade Tubing – 4 pc (Red, White, Yellow and Blue)

- Change RO Membrane every 18-24 months or as required.
- Change Inline Carbon Filter every 6-12 months or as required.

If you will be away or not using the unit for an extended period of time, please disconnect unit from power supply. If the unit has been shut down and not used for an extended period of time, perform the same flushing procedure as in the initial set up.

Filter Replacement



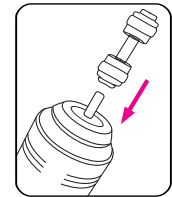



- Close Feed Water Valve.
- Close Tank Ball Valve on Pressure Tank.
- Open Faucet and drain any remaining water from system.
- Disconnect quick connect filters.
- Replace filters, reconnect, and open valves.
- Perform pre-filter flush after filters have been changed



Note: Diagrams on how to connect using quick connect fittings can be found in the installation section.

Membrane Replacement

- Close Feed Water Valve.
- Close Tank Ball Valve on Pressure Tank.
- Open Faucet and drain any remaining water from system.
- Open membrane housing and remove used membrane.
- Follow the same procedure as RO membrane installation to replace RO membrane.

- When the unit is operating normally and producing water, the screen will show “ ”. At the same time, TDS and water temperature will be displayed.
- When Pressure Tank is full, LCD will display “ ” along with TDS. 5 sec after tank is full, the unit will flush for 8 sec. When water is used, unit will automatically resume operation.
- When unit has been operating for 7.5 hours continuously, unit will flush automatically for 1 minute and 30 sec.
- Each cartridge change reminder indicator contains 5 levels “”. Each level is set for 3 months (depending on water usage) and will slowly disappear one level at a time.
- When all the levels have disappeared, the indicator will blink and an alarm will sound signaling the filter needs to be changed. To reset the indicator after the filter has been changed hold down the “**Affirm**” button. If you wish to manually flush the unit, press the “**Strong Flush**” button, the LCD will show “ ” and unit will automatically flush for 1 minute and 30 sec, the TDS indicator will count down to zero.

Filter Maintenance

To ensure the unit operates at its optimum level, routine maintenance is required. The frequency of maintenance depends on the feed water quality and amount of system usage. The following are some guidelines for scheduled filter changes, keep in mind the frequency of filter changes may vary. If in doubt, contact your local dealer or service technician.

- Change Spun PP Filter every 3-6 months or as required.
- Change Block Carbon Filter every 6-12 months or as required.

Faucet – 1 pcs

Accessories – Tube Plug, Screws, Drain Clamp, Tee Fitting, Ball Valve, Feed Water Valve

RO Membrane – 1 pcs

Manual – 1 pcs

TECHNICAL SPECIFICATIONS

Voltage and Frequency: 110V-240V 50Hz/60Hz

Wattage: 25W-36W

RO Element Capacity: 50/75/80/100/125 GPD

Tank Capacity : 3.2G Steel or 3.0G Plastic

Inlet TDS: ≤ 250ppm

Chlorine Level: ≤ 0.2ppm

Average RO Rejection Rate: 98%

Inlet Water Pressure (min/Max): 14.5 - 43.5 psi

Inlet Water Temperature (min/Max): 5°C - 45°C

Flush Type (model dependent): Auto or Manual

BEFORE YOU START

- Read through all instructions before beginning installation and using this system. Follow all steps exactly or risk damaging system/incorrect operation.
- This system contains filters that need to be replaced at certain intervals. Replacement intervals will vary according to use, please contact your local dealer for details.
- Please install system on potable water only. On non-potable water sources, system will not function properly and additional pre-treatment may be needed.

- Ensure source water pressure is between **14.5 - 43.5 psi**. If source water pressure exceeds maximum pressure a pressure reduction valve may be needed, consult your local dealer.
- Ensure source water temperature is between **5°C - 45°C**. System will not function properly if these temperatures are exceeded. **DO NOT INSTALL ON HOT WATER SOURCE.**
- Do not use system on noticeably contaminated water such raw sewage or well water.
- This unit operates on **110V~240V** power. Please ensure you are using the correct power source.

CAUTION:

- Do not disassemble, open, or modify this unit. Tampering with the unit may cause failure or damage and will void warranty.
- Do not cover the unit, as this will prevent proper heat dissipation and can cause damage or fire.
- Do not place objects on top of the unit as this may cause damage to the unit and may cause leaking.
- Follow all recommended operating pressures and temperature, failure to do so will cause damage to the unit and void warranty.



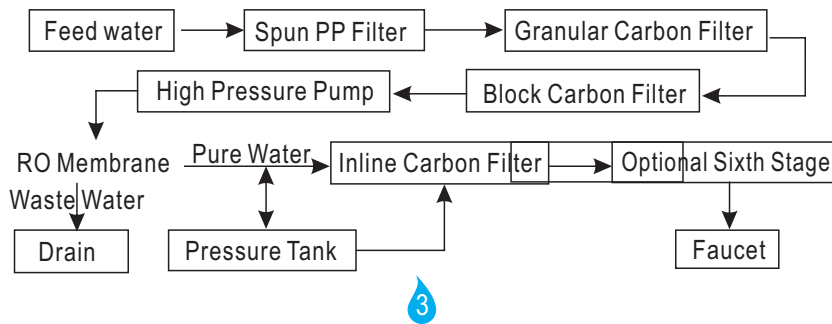

HOW YOUR SYSTEMS WORKS

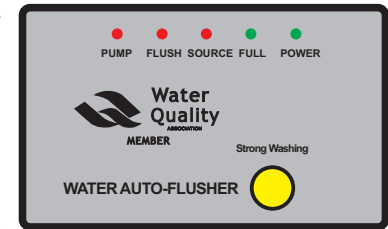

- And then enters into the state of producing water, the indicating lamp **PUMP** will light.
- When producing water full, the indicating lamp **FULL** will light, the **PUMP** indicating lamp extends for 10 seconds and then extinguish. (After water used, enters into the water producing state again.)
- When water pressure is too low or there is no feed water, an alarm will sound and **SOURCE** light will blink.
- When unit has been operating for 7.5 hours continuously, unit will flush automatically for 1 minute and 30 sec.
- If the machine longtime working doesn't stop, the machine alarms and stops automatically, all the indicating lamps are blink. (**Note:** Please make the machine stop working, examine & repair or exchange the Membrane.)
- If you wish to manually flush the unit, press the **Strong Flush button**.



⊙ LCD Display and Control Panel for C Series

- 5 seconds after power up, unit will automatically flush for 1 minute and 30 sec. LED display will show an “ ” and display will show current temperature and cartridge change reminder.
- When water pressure is too low or there is no feed water, an alarm will sound and LCD will show “ ”. The TDS display will show “----”



Note: Pump and membrane may be severely damaged if system is run without flushing pre-filters. Discard all water from flush, it is not suitable for use or consumption.

- 💧 After flushing pre-filters connect and open all valves.
- 💧 Wait approximately 2 minutes before opening faucet.
- 💧 Allow system to flush for first 10-15 minutes with faucet open.
Do not use water from RO unit at this time.

🕒 Flushing the Pressure Tank

- 💧 After flushing the Pre-Filters, allow the unit to operate and fill the Pressure Tank.
- 💧 Tank will take approximately 3.5 hours to fill. Once tank is full, discharge Pressure Tank by leaving faucet open.
- 💧 Once Tank is completely empty, close faucet and allow tank to fill again.
After the Pressure Tank has been flushed, the unit is ready for use.

After flushing the system is ready to use.

🕒 Regular Operation

Once system has been set up and has been plugged into a power source, it will operate and begin treating water automatically the faucet is open. Once the faucet is closed, the unit will switch off automatically. After use, the unit will flush automatically if equipped with auto flush function.

🕒 Indicator Display and Control Panel for B Series

- 💧 5 seconds after power up, then **FLUSH** will light up, unit will automatically flush for 1 minute and 30 sec.

SYSTEM COMPONENTS

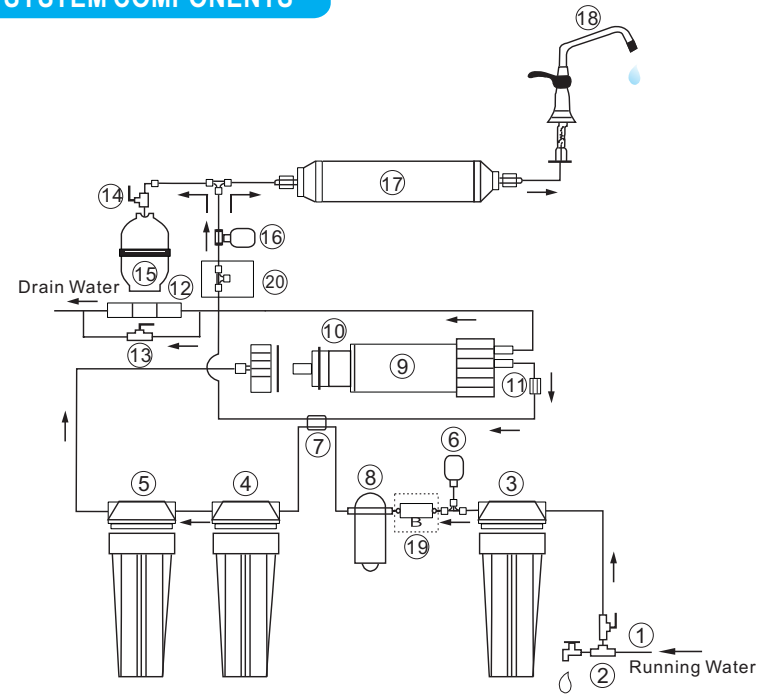

- | | | |
|------------------------------------|---|------------------------|
| 1. Feed Water Valve | 2. Tee Fitting | 3. PP Spun Fiber |
| 4. Granular Carbon Filter | 5. Block Carbon Filter | 6. Low Pressure Switch |
| 7. Auto Shut Off Valve (option) | 8. Booster Pump | 9. Membrane Housing |
| 10. RO Membrane | 11. Check Valve | 12. Drain Restrictor |
| 13. By-pass flush Valve (option) | 14. Ball Valve | 15. Pressure Tank |
| 16. High Pressure Switch | 17. Inline Carbon Filter | 18. Faucet |
| 19. Inlet Solenoid Valve (option) | 20. Water quality detector (B & C Series only) | |

INSTALLATION

Tools and Parts Required



Knife



Electric Drill



Seal Tape



Hammer



Monkey Wrench



Scissors

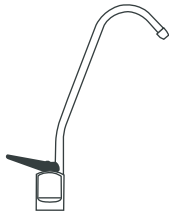

Faucet

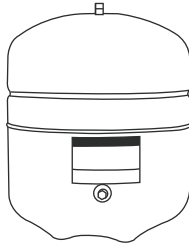

Tank

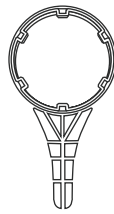

Housing Wrench

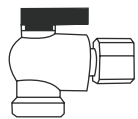

Tank Ball Valve

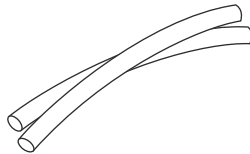

Water Pipe

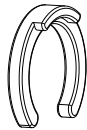

Clip

Step 4. Plug the **Adaptor** (Item G) to the **UV Lamp** (Item F). See Figure 4.

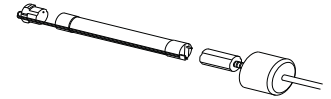

Step 5. Insert the **UV Lamp** (Item F) into the **UV Chamber** (Item A). See Figure 5.

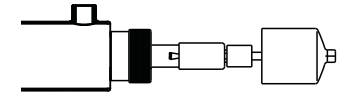

Step 6. Seal it up with the Rubber Stopper that is already attached to the **Adaptor** (Item G). See Figure 6

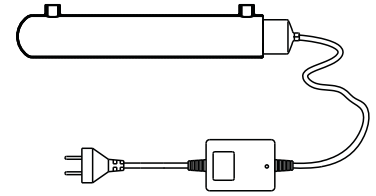

WARNING!!!

Do not watch the ultraviolet rays emitting out of the UV lamp without protection since they will cause serious burn for naked eyes. Unplug the electrical ballast when maintaining the system.



OPERATION AND MAINTENANCE

Pre-filter Flushing (initial setup, before installing RO Element)

Prepare system for operation by flushing pre-filters:

- Disconnect RO element inlet tube on element housing cap. Open water main and inlet valve and allow system to run through the 3 pre-filters.
- Discard output water into container or drain.
- Continue flushing until output water is visibly clean. Reconnect tube.

⦿ Install Ultraviolet Sterilizer

A. UV CHAMBER

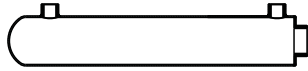

B. GLASS TUBE

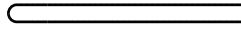

C. ALUMINUM NUT



D. SILICONE STOPPER



E. SILICONE SEAL



F. UV LAMP

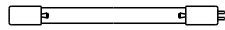

G. ADAPTOR

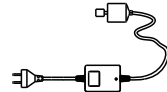

Step 1. Place **The Silicone Stopper** or **Silicone Seal** (Item D OR E) at the tip of **Glass Tube** (Item B). See Figure 1.

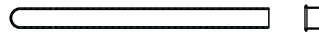

Step 2. Slide-in the **Glass Tube** (Item B) into the **UV Chamber** (Item A). See Figure 2.

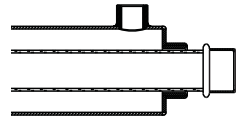

Step 3. Fasten the **Aluminum Nut** (Item C) to seal the **UV Chamber** (Item A). See Figure 3.



Faucet Bracket



RO Membrane

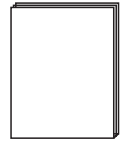

Manual



Feed Water Valve

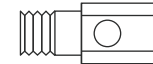

Tee Fitting

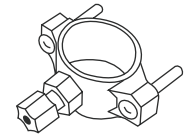

Drain Clamp

⦿ Unit placement

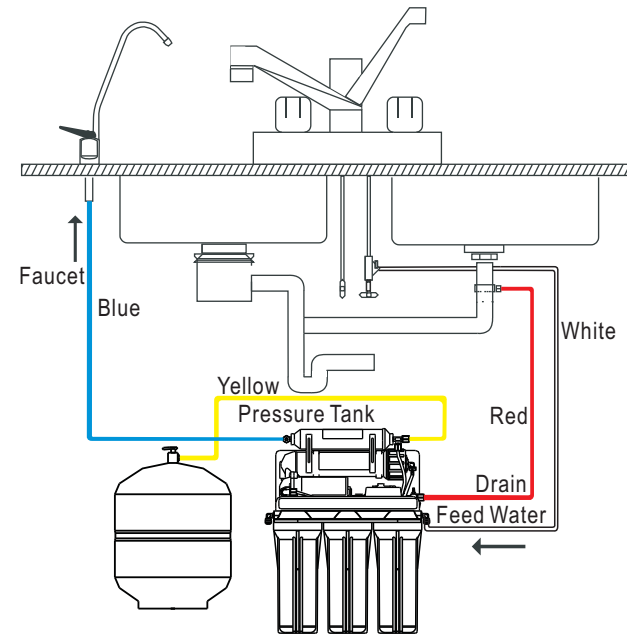

- The unit can be placed flat or upright and on top, inside, or under the cabinet. Feed Water connection should be as close as possible to unit. However, if due to space or other limitations, this unit can be placed where it is convenient.
- When choosing a location for the unit, remember to have easy access to cold water line, drain pipe, power outlet, and enough room to change filters.

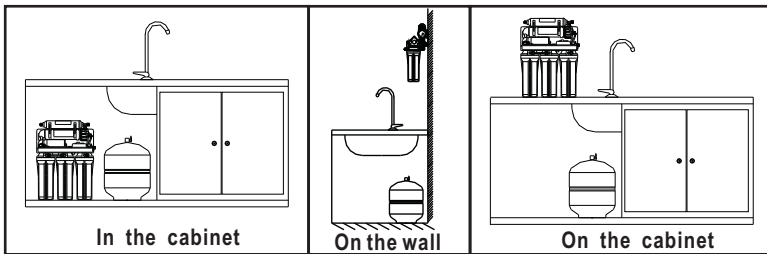

NOTE: All components and tubing should be located in an area not exposed to freezing temperatures or direct sunlight.

⦿ Drain Clamp Installation

- Position drain clamp on drain pipe above the drain trap and tighten securely.
- Using the drain clamp as a guide, drill a 6mm hole, enough for the 1/4" tubing to pass, through one side of the drain pipe. **DO NOT** drill through both sides.
- Connect **Red Waste Water Tubing** from unit to Drain Clamp.

⦿ Install Tank

- Hand tighten plastic.
- Shut-off valve to tank.
- Then connect yellow color tubing.

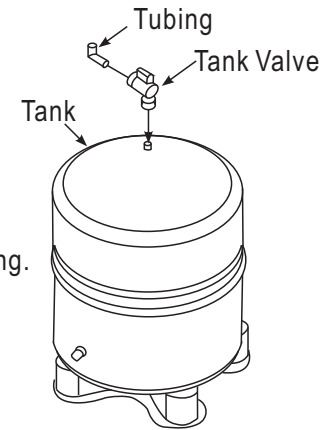

⦿ Install RO Membrane Element

NOTE: Before proceeding with membrane element installation, please flush pre-filters thoroughly. (Instructions on how to perform filter flush provided in next section)

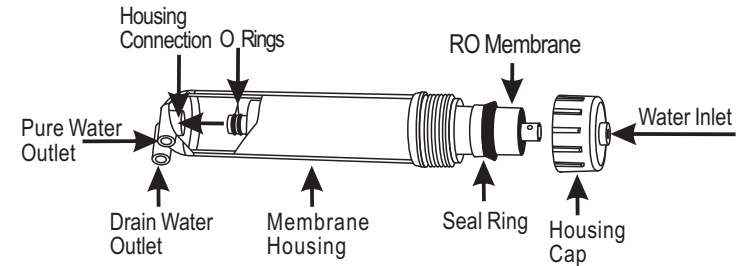

- Remove RO housing cap using wrench.
- Remove RO element from packaging.
- Insert RO element into housing with the small double O rings facing inward.
- Install membrane housing cap and tighten with wrench provided.

- Attach **Blue Pure Water tubing** to the bottom of faucet and connect tubing to unit.

CAUTION: Check that tubing is connected correctly according to Connection Diagram at beginning of section.

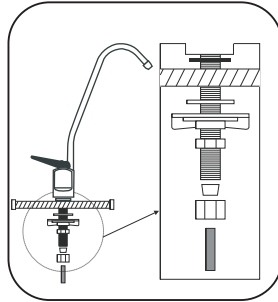

Install Pre-Filters

- Remove Pre-Filters from packaging.
- Place filters in appropriate housings according to labels and install filter housing from right to left in the following order: PP, GAC, CTO.
- Tightening housings with wrench provided.

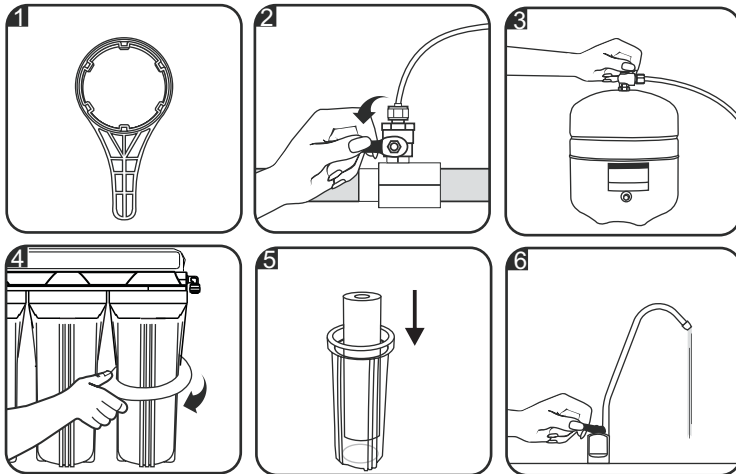

Note: When installing housings make sure housing is level and even to avoid leaking.

NOTE: When cutting the tubing make clean, square, cuts, failing to do so result in poor connection and possible leaks.

CAUTION: The lowest point of the line should be the point of connection to the Drain Clamp. There should be no sag in the line as this may cause excessive noise as the reject water is flowing to drain.

DRAIN CLAMP ASSEMBLY

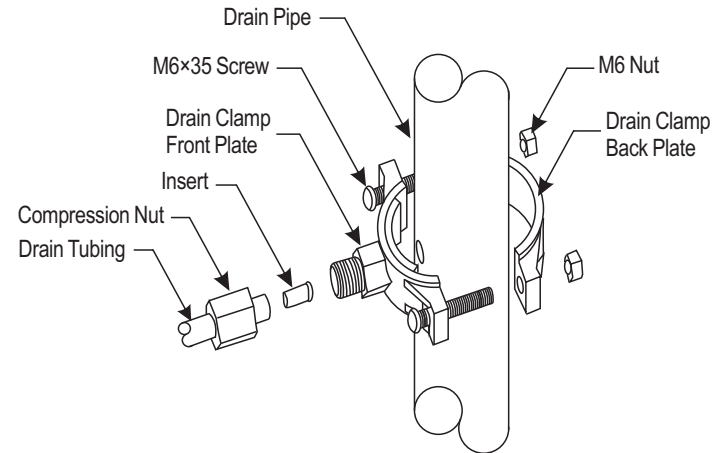

Feed Water Valve and Tee Fitting

- Install Tee Fitting and Feed Water Valve as per diagram.
- Wrap threads of Feed Water Valve and Tee Fitting with Teflon tape.
- Connect White Feed Water Tubing from unit to Feed Water Valve.

Install the Feed water valve

Install the Feed water valve Tee fitting, and then connect to source water.

Caution: The water supply to your unit **MUST** be from **COLD WATER LINE**.

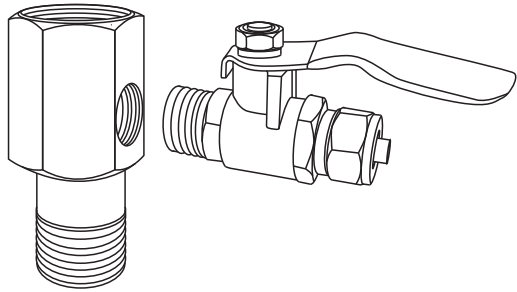

NOTE: Use only a **cold potable water** supply as Feed Water, hot water will damage your unit. Softened Feed Water will extend the life of the RO Membrane.

Pressure Tank

- Keep Pressure Tank within 10 feet of faucet.
- If longer length of tubing is needed, use 3/8" tubing only to prevent pressure drop.
- Tank can weigh up to 30lbs when full, find firm and level flooring.
- Install Ball Valve by screwing Valve on to Tank and apply Teflon tape to prevent leaking.
- Connect Red tubing from post filter to Pressure Tank.

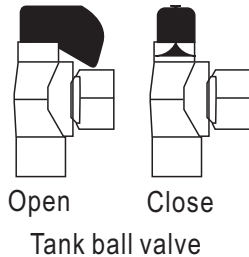

⦿ Tubing Connection

Refer to the following diagram for how to properly install the Quick fittings and JACO fittings.

Quick Fitting

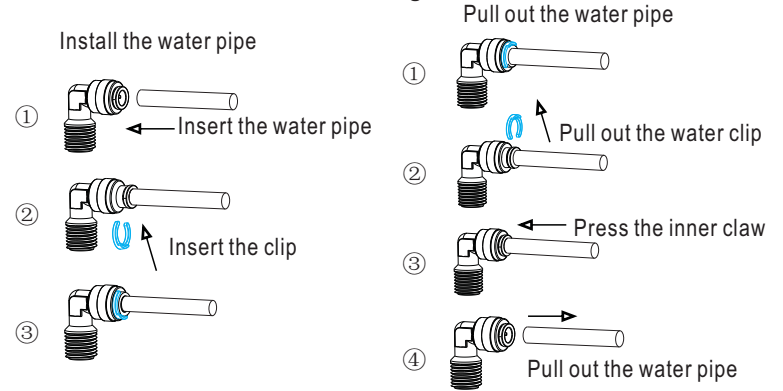

JACO Fitting

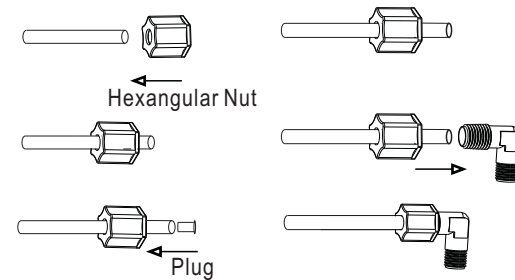

⦿ Faucet Installation

- Select a convenient location near your sink to place the faucet.
- Drill a hole 12mm in diameter in counter top.
- Place washers, plates, seals and nuts in order as per diagram and tighten on to counter.